



Making Your Job More Enjoyable

VA3-P7-EX Vacuum Pump

ATEX-Certified*

A1 A2L A2 A3

R290, R600a etc.



VALUE Mechanical & Electrical Products CO., LTD

Add: No. 5, 3rd. Street, East Industrial Park, Wenling, Zhejiang, China

Tel: +86-576-86191959

Fax: +86-576-86191957

Email: value@worldvalue.cn

www.worldvalue.cn

VALUE • Quality Assurance



TABLE OF CONTENTS

Certifications	01
Introduction and technical information	02
AC Motor Driven Vacuum Pumps	02
Application	02
Special features	03
Preparation prior to using vacuum pump	03
Safety warnings	03
Use guide	04
Maintenance	05
Requirement for warranty coverage	06
Additional safety instruction	07
Troubleshooting	08
Exploded view	09
Repair parts list	10
Dimension	11

CERTIFICATIONS

Certified and tested according to:

- EN IEC 60079-0:2018
- EN IEC 60079-7:2015+A1:2018
- EN IEC 60079-15:2019
- EN 60079-11:2012
- EN ISO 80079-36:2016
- EN ISO 80079-37:2016

CE II 3G Ex ec ic nC h IIA T4 Gc

CE	Denotes that this product complies with ATEX directives Certificate No. is CSANe 22ATEX1160X
	Specific marking for explosion protection
3	Zone 2
G	Gas
Ex	Denotes explosion protection
ec	Increased safety
ic	Intrinsic safety
nC	Sealed device
h	Constructional safety
IIA	Typical gas - R290, R600a etc.
T4	135°C
Gc	EPL - Equipment Protection Level

 **WEEE**
(Do not dispose through
typical waste streams)

Correct disposal of this product:

Correct disposal of this product: This marking indicates that this product should not be disposed with other household wastes. To prevent possible harm to the environment or human health from uncontrolled waste disposal, recycle it responsibly to promote the sustainable reuse of material resources. To return your used device, please use the return and collection systems or contact the retailer where the product was purchased. They can take this product for environmental safe recycling.

INTRODUCTION AND TECHNICAL INFORMATION

In order to make it easier to understand the components of the vacuum pump, please see the picture below.



AC MOTOR DRIVEN VACUUM PUMPS

Model	VA3-P7-EX
Power Supply	230V-50/60Hz
Flow Rate (CFM)	7 CFM
Ultimate Vacuum	15 microns
Pump Design	Dual-Stage, AC Motor
Oil Capacity (ml)	426
Dimensions (mm)	346×130×287
Weight (kg)	11.8
Inlet Port	1/4", 3/8" Flare

APPLICATION

VALUE VA3-P7-EX vacuum pumps are used to remove air, moisture, and other non-condensables from sealed HVACR systems. The products can be used for evacuation of HVACR repair and new installations. For use on refrigeration systems utilizing Class A1 (nontoxic, nonflammable), Class A2L (nontoxic, low flammability) and Class A2 (nontoxic, flammable), and Class A3 (nontoxic, flammable).

A3 Refrigerants							
Applicable	R50	R170	R290	R600	R600a	R601	R601a
		R1270	R430A	R431A	R433A	R433B	R433C
	R436B	R441a	R443A	R511A			
Not applicable	R702	RE170	R1150	R429A	R432A	R435A	R510A

SPECIAL FEATURES

- Integrated pump structure, high precision, for deep ultimate vacuum level.
- Forced oil lubrication ensures vane sealing, cooling and high reliability.
- Large and easy to see oil-level window design help prevent oil supply shortage.

PREPARATION PRIOR TO USING VACUUM PUMP

1. Verify the power supply being used to match the voltage on the nameplate.
2. Ensure that the pump is switched off prior to connecting to the power source.
3. Check for proper oil level, or change if needed.
4. Remove the oil fill cap, filling oil to the level in between the two oil sight glass lines, as shown in the drawing below. For specific pump oil volume, please see the technical specification table.

Note: In order to prevent pump oil from spilling out, please add oil slowly.

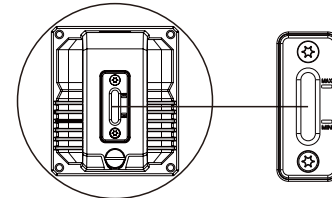

Switch on the power and the pump will begin to operate. After running for approximately one minute, check the oil level. If the oil level is too low, switch off the machine and add the required extra oil. Reinstall the oil fill cap.

Note: While the pump is operating, the oil level should be in between the two oil position lines. If the oil level is too low, it will reduce the performance and could damage the pump vanes. If the oil level is too high, it could cause oil to discharge through the pump exhaust.

SAFETY WARNINGS

WARNING:

This machine should only be used for evacuation of refrigerant systems after refrigerant has been removed from the system and the system has been opened to atmosphere. This machine is not to be used as a transfer pump for liquids or any other media; doing so can damage the product.

Note: In order to avoid personal injury, please carefully read and follow the instructions in this user manual and the user guide of the pump.

SAFETY WARNINGS

1. Never connect a vacuum pump to a pressurized system. Always check to make sure that system and piping pressure is not above atmospheric pressure.
2. When handling refrigerants, please wear an eye-protection such as safety glasses or goggles.
3. Avoid direct physical contact with refrigerants, you will get burned.
4. When connecting the power source, all equipments must be grounded in order to prevent electrical hazards.
5. When the pump is in operation, the enclosure surfaces will be hot. Do not touch the oil box or the motor case. Allow adequate ventilation space for heat dissipation.
6. Keep pump dry and away from water, mud, and dirt at all times.
7. Operating pump with intake fittings open to the atmosphere must not exceed 3 minutes.
8. Ambient temperature range for pump use is -1°C to 40°C (30°F~104°F). The pump can be used in lower ambient conditions, if warmed up inside first and run for no more than 1 minute to warm the oil prior to system evacuation.
9. The power outlet must be grounded.
10. Prior to connecting the vacuum pump to an A/C-R system, please use proper methods to remove refrigerant from a pressurized system. Note that pumping refrigerants under high-pressure conditions will damage the pump, and refrigerant must be removed using a recovery machine designed for that purpose.

USE GUIDE

CAUTION

-To reduce the risk of electric shock, do not expose to rain.
Store indoors.

EXTENSION CORDS

If an extension cord must be used, be sure it is:

1. A 3-wire extension cord that has a 3-blade grounding plug, and a 3-slot receptacle that will accept the plug on the product
2. In good condition
3. No longer than 15.2m (50')
4. 16 gauge (AWG) or larger. (Wire size increases as gauge number decreases. 14 AWG and 12AWG may also be used. DO NOT USE 18 AWG)

NOTICE: When using an extension cord, be sure to use one heavy enough to carry the current your product draws. An undersized cord results in a drop in line voltage and loss of power and overheating.

1. When using the vacuum pump, remove the inlet protection cap from the desired (5/8" - 18UNF, 7/16" - 20UNF) connecting port, as shown in the diagram above, and connect the pump to the system or piping to be evacuated. Use shortest hoses possible for faster and more thorough evacuation.
2. Inspect the hose inlet connection, as well as all connecting hoses for proper seal. There must be no leakage or it will be impossible to draw the required deep vacuum level.
3. At the beginning of the evacuation process, open the GAS BALLAST, and once the vacuum gauge reaches 2000 microns, retighten to achieve desired vacuum level.

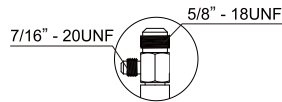

4. After evacuation is completed, shut down the pump and close the system access valves.
5. Turn off the power switch on the pump and disconnect power.
6. Remove the evacuation hoses.
7. Close the air entry cap and the air exhaust cap tightly (with the exception of models without air exhaust cap), to prevent dirt or particulates from entering the pump.

Note:

1. Always evacuate systems in conjunction with a micron vacuum gauge, such as the NAVTEK VMV-1, giving you a comprehensive view of the sealed system internal evacuation condition.
2. Please pay attention to any changes in the oil level during pump operation. If the oil level falls below the center line, immediately add more vacuum pump oil to avoid damage to the pump.
3. Vacuum pump and oil must be above -1°C.

MAINTENANCE

1. Vacuum pump oil has three major functions: pump lubricant, pump cooling, and pump sealant. During the evacuation process, the pump oil will absorb moisture being pulled from the system, causing it to be less effective as a lubricant and pump vane seal, extending evacuation time and possibly allowing the pump to overheat. We recommend that the oil be changed just before evacuating each A/C-R system to insure the pump oil is in a clean condition as this is the key factor in determining if the pump can achieve the required vacuum levels. In order to maintain the optimum operation of the pump, we recommend that you use NAVTEK vacuum pump oil. This oil is made using a unique process and can maintain proper viscosity during normal operation and temperatures, and it's also helpful for cold starts. Should the NAVTEK oil not be available, reputable brands of special-purpose vacuum pump oil may be used.

Note: Should the pump oil become opaque, dirty, or full of moisture, promptly change oil. This will greatly speed up evacuation, especially when there is a lot of moisture in system piping from having been left open to the atmosphere for an extended period of time.

Oil change procedure:

1. To ensure that the pump and oil are warm, run pump for approximately one minute prior to changing oil. Do not run longer than this, as it may be possible to damage the pump.
2. While the pump is running, open one inlet port and allow oil to drain out of the pump. After turning off pump, open the oil drain plug, and drain used oil into an appropriate vessel and dispose of properly.
3. As oil stops draining, tip the pump to drain any remaining oil in the bottom of the pump.
4. Close oil drain valve.
5. Remove oil fill cap, pour in new oil until the oil is at the proper level in the sight glass (the same procedure prior to using the pump above).

REQUIREMENTS FOR WARRANTY COVERAGE

Product warranty is provided for product quality problems for one years from date of sale. For warranty to be valid, the following conditions must be met:

1. Products issues due to manufacturing defects confirmed by qualified agents.
2. Products which have not been maintained or dismantled by unauthorized parties.
3. Products that have been used in accordance with the User Manual. All maintenance services shall be performed during the warranty period.

Statement: Other than repairing the product defective, the manufacturer of this product will not be liable for any other costs, such as time spent in fixing the issue, refrigerant consumption, refrigerant disposal costs, as well as unauthorized transportation and labor costs.

ADDITIONAL SAFETY INSTRUCTION

Additional Safety Instructions for refrigeration systems containing Flammable refrigerants.

Besides existing occupational hazard procedures or other regulations that may be required by local, state or federal agencies, the following are additional safety recommendations when servicing refrigeration equipment that contain Class A2L, A2 or A3 refrigerants.

The area of service should be marked as Temporary Hazardous Zone. This will be an area with a radius of 3m centered on refrigeration equipment being serviced and should have no smoking and other hazardous signs posted. Local supervisor should be notified of the zone's existence.

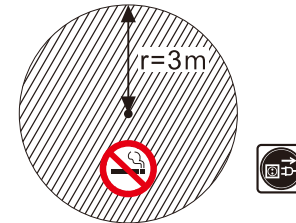

- Refrigeration equipment being serviced

Division (zone) 2

- Ensure the refrigeration equipment's power has been discontinued during maintenance work.
- When connecting service equipment (such as vacuum pumps, scales, recovery units) to a power source, the connection must be made outside the Temporary Hazardous Zone.
- Factory-equipped power cord of VP7DPF is 3m, which can make sure the connection is made in the area free of ignitable concentrations. Do not change the power cord at will.

TROUBLESHOOTING

Malfunction	Possible Cause	Remedy
Low Vacuum	1. Secondary air inlet connection cap loose on the air inlet port.	Tighten the cap.
	2. Damaged rubber ring inside the secondary air inlet connection cap.	Replace the rubber ring.
	3. The volume of oil is insufficient.	Add oil to the center line of the oil display.
	4. Pump oil becomes opaque or absorbed too many impurities.	Replace with new oil.
	5. The pump's oil entry hole is clogged or the oil supply is insufficient.	Clean the oil entry hole, clean the oil filter.
	6. The pump connecting hoses, manifold or system has a leak.	Inspect the connecting hose gaskets and system, repair leaks.
	7. The pump selection is wrong.	Check the size of the container to be evacuated, recalculate and select an appropriate pump model.
	8. The pump has been used for too long, damage and wear to components caused increased gaps between parts.	Inspect and repair, or replace the pump.
Oil leak	1. Damaged oil seal.	Replace the oil seal.
	2. Loose or damaged oil box connections.	Tighten the connecting screws, replace O-rings.
Oil spray	1. Excessive oil volume.	Remove oil until the oil position line is reached.
	2. Inlet port pressure is excessively high for a long period.	Select an appropriate pump, increase the pumping speed.
Start-up problems	1. Oil temperature is too low.	Place the vacuum pump in an over 77°F ambient environment for an hour, or replace in the 77°F oil.
	2. Motor, power source or circuit board malfunctions.	Inspect and repair.
	3. Foreign objects entered the pump.	Inspect and remove.
	4. Voltage supply is excessively low or high.	Inspect the power source voltage.
	5. Overload trips.	After overload trip occurs, turn off the switch. Remove the power plug. Examine and solve the issue.

Notes:

1. The pump has over-current / overload protection, please troubleshoot after overload resets.
2. If the above methods cannot resolve your problems, please contact your nearest distributor or take the pump to a repair center. We will do our best to provide you with a quick turnaround to keep you working.

EXPLODED VIEW

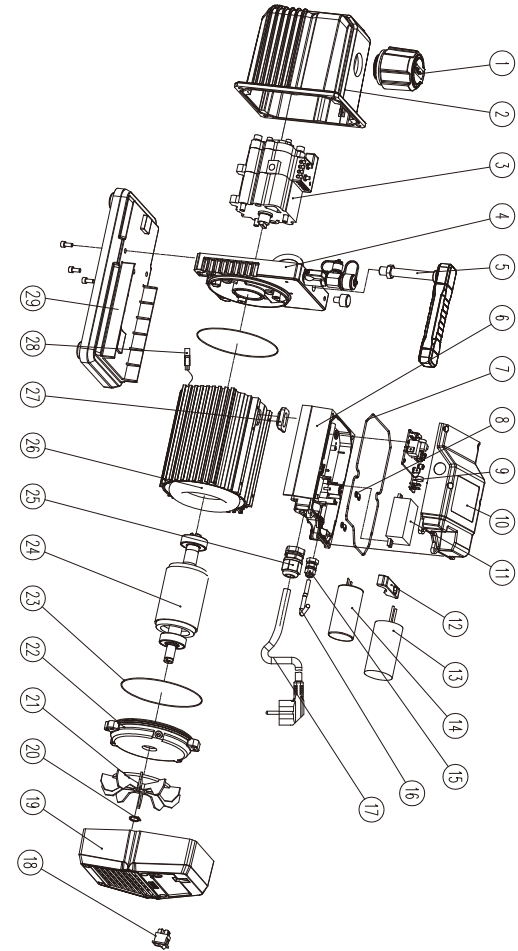

REPAIR PARTS LIST

Ref No.	Part Name
1	Catcher
2	Oil Tank
3	Pump head
4	Bracket
5	Handle
6	Capacitor Box
7	Sealing Rings
8	Pressing power supply
9	Switch power supply
10	Top cover of capacitor box
11	Electronic Starter
12	Capacitor Platen
13	Running Capacitor
14	Starting Capacitor
15	1xΦ6 cable gland
16	Switch cable
17	Power supply cord
18	Power switch
19	Rear cover
20	Retaining ring
21	Fan blade
22	Rear cover of motor
23	Sealing ring
24	Rotor assembly
25	1xΦ10.2 cable gland
26	Stator assembly
27	Threading ring
28	Thermal protector
29	Base

DIMENSION

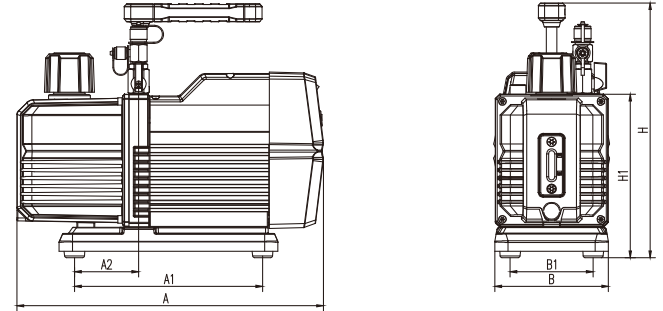

Unit:mm

Model	A	A1	A2	B	B1	H	H1
VA3-P7-EX	346	212	72.2	130	93.6	287	184

